

FALCO 600 Catalyst Replacement Procedure

1.0 REQUIRED EQUIPMENT / TOOLS

Personal Protective Equipment (PPE) required:

- Safety Glasses
- Gloves
- Long sleeve shirt and pants
- Dust mask
- Lockout/Tagout materials
- Hearing protection
- MSDS for catalyst (additional PPE may be required)

Other Tools / Equipment Required:

- Shop Vac
- Flashlight
- Catalyst
- Container for used catalyst
- Funnel with 3/4" discharge (Large plastic soda bottle works well).
- Scoop -can be made from a large detergent bottle (must be clean).
- Pipe wrench
- Approximately 6 ft of 3/4" pipe / conduit in two foot sections (suction pipe).
- Falmouth Products Shaker Kit
(NOTE: use of other shaking methods may damage equipment)
- Step ladder
- 3/4" box wrench (pipe cap removal)

1.1 CATALYST REMOVAL:

1. Cool the FALCO 600 by either leaving off for several days or running with the heater off and the heat exchanger bypass valve open until all temperatures are below 40°C.
2. Turn the FALCO power switch off, and Lockout/Tagout the power supply to the FALCO 600 and blower. *NOTE: the FALCO 600 has multiple sources of electrical supply!*



**CAUTION! Confirm that FALCO and blower cannot be turned on!
Blower operation during the replacement process may result in personal injury and economic loss!**

3. Safely position step ladder next to the FALCO 600.
4. Remove the discharge stack extension from the FALCO 600 (6" T-bolt clamp).
5. Put on Personal Protective Equipment: Dust mask, Safety Glasses and Gloves.
6. Remove the (2) **2"** and (2) **1 1/4" fill pipe caps** on the top of the unit (3/4" wrench).

FALCO 600 Catalyst Replacement Procedure

1.1.1 CATALYST REMOVAL FROM BOTTOM:

1. If unit is installed with adequate clearance (>4") between the bottom of the frame and the floor/ground, the catalyst may be removed from the bottom. Otherwise, proceed to step 1.1.2.
2. Slide a large tray beneath the unit, positioned below the **1-1/2" catalyst drain**. Total volume of catalyst is approximately 35 gallons.
3. Remove the **1-1/2" pipe cap** on the drain port with a 3/4" wrench. NOTE: Older models may require a pipe wrench for drain cap removal. *Be ready! When cap is removed, catalyst will pour out quickly.*
4. If catalyst beads stop flowing, it may be necessary to vibrate the vessel if catalyst is still present (inspect through top fill ports). Attach *Shaker* as described in section 1.3 and continue until the flow of beads stops.
5. When all catalyst has been removed, re-install the 1-1/2" pipe cap with a sufficient amount of sealant (Rectorseal No 5).

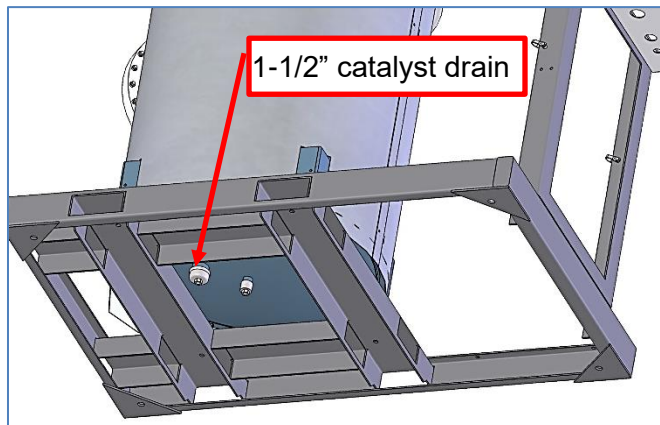

1.1.2 CATALYST REMOVAL FROM TOP:

1. If catalyst cannot be removed from the bottom, prepare a Shop Vacuum by attaching a length of 3/4" suction pipe to its hose with Duct tape
2. Turn on the Shop Vacuum and insert the suction pipe thru the fill ports. Vacuum until all catalyst is removed. Empty Shop Vacuum as necessary.
3. If catalyst beads stop flowing, check vacuum hose for clogs and check capacity of Shop Vacuum. It may also be necessary to vibrate the vessel. Attach *Shaker* as described in section 1.3 and continue vacuuming catalyst until the flow of beads stops.

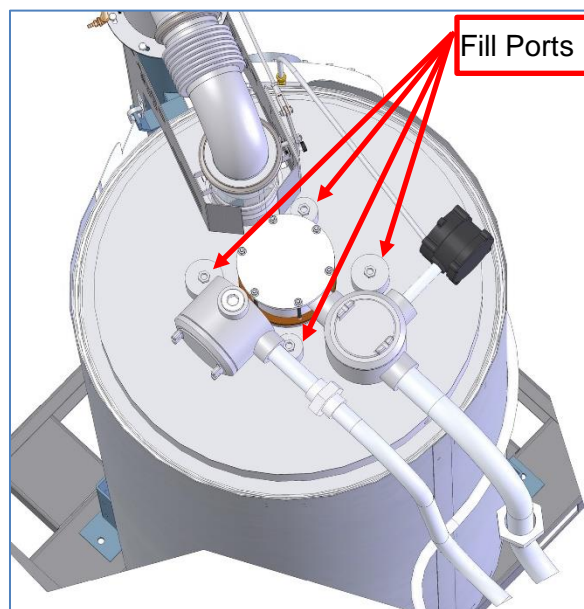

CAUTION! Be aware of the position of the FALCO 600 during vibration, especially if not secured to the ground.

FALCO 600 Catalyst Replacement Procedure

1.2 CATALYST REPLACEMENT:

1. Prior to replacement, inspect the empty catalyst chamber with flashlight. There are screened walls on either side of the chamber. The walls and chamber should be clean and not have any holes large enough to pass catalyst pellets.

If you have questions or concerns about the integrity of the catalyst chamber contact Falmouth Products before proceeding.

2. Ensure that the 1-1/2" catalyst drain cap (located on bottom) is in place.
3. Safely position step ladder next to the FALCO 600.
4. Use scoop to pour new catalyst into the catalyst chamber through the 2" fill ports until the catalyst chamber is 1/3 full.
5. Attach *Shaker*. Follow directions in step 1.3.



CAUTION! Before shaking secure control panel and confirm that nothing was placed on top of the unit that could fall off during vibration (like the catalyst fill caps).

6. Plug shaker into 120V power source. Follow directions in step 1.3.
7. Continue filling catalyst chamber through the 2" and 1 1/4" fill pipes on top of the unit until catalyst is almost to the top of the fill pipes. Use a long thin screwdriver to gently distribute the catalyst.
8. Unplug shaker and remove.
9. Replace fill caps. Use high-temp anti-seize on threads. *Do not overtighten!*
10. Catalyst may settle after operation and should be topped off again after 2 weeks of operation.

FALCO 600 Catalyst Replacement Procedure

1.3 CATALYST SHAKER INSTRUCTIONS:

Shaker is required for optimal catalyst compaction. If the shaker is not used catalyst performance may be affected.

Included in this kit are:

- Shaker / mounting plate
- (2) C-Clamps



Caution! Before shaking, secure control panel (tighten thumb screws) and confirm that nothing can fall during vibration.

1.3.1 SHAKER ATTACHMENT:

1. Position *Shaker* onto the FALCO 600 flame arrester in the location shown. Large holes in the rear of the mounting plate should be positioned over the two uppermost bolt heads

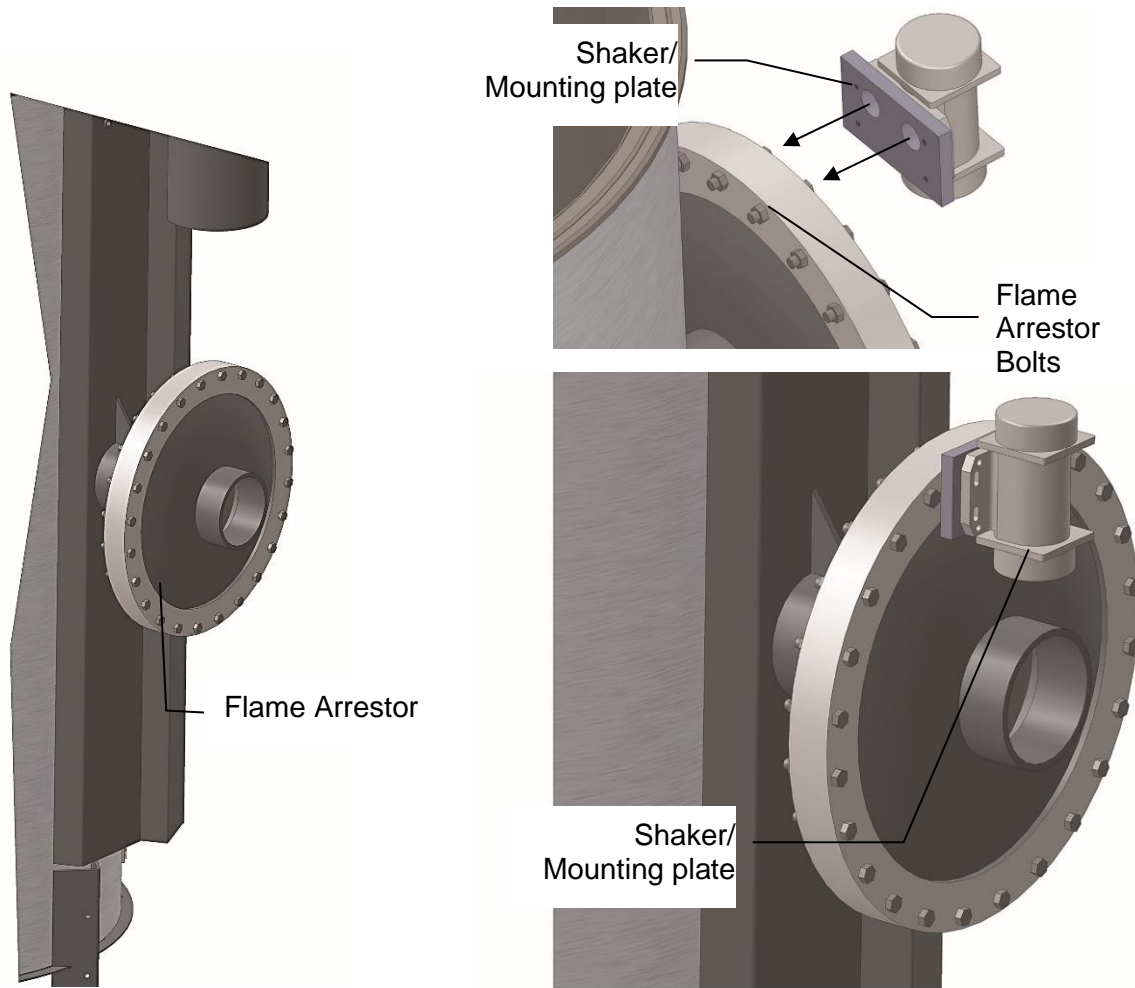

FALCO 600 Catalyst Replacement Procedure

2. Clamp shaker to flame arrester with two C-Clamps. Clamps should engage base of shaker near upper mounting holes and rear of flame arrester plate (not bolt or nut). Ensure that clamps are firmly attached.

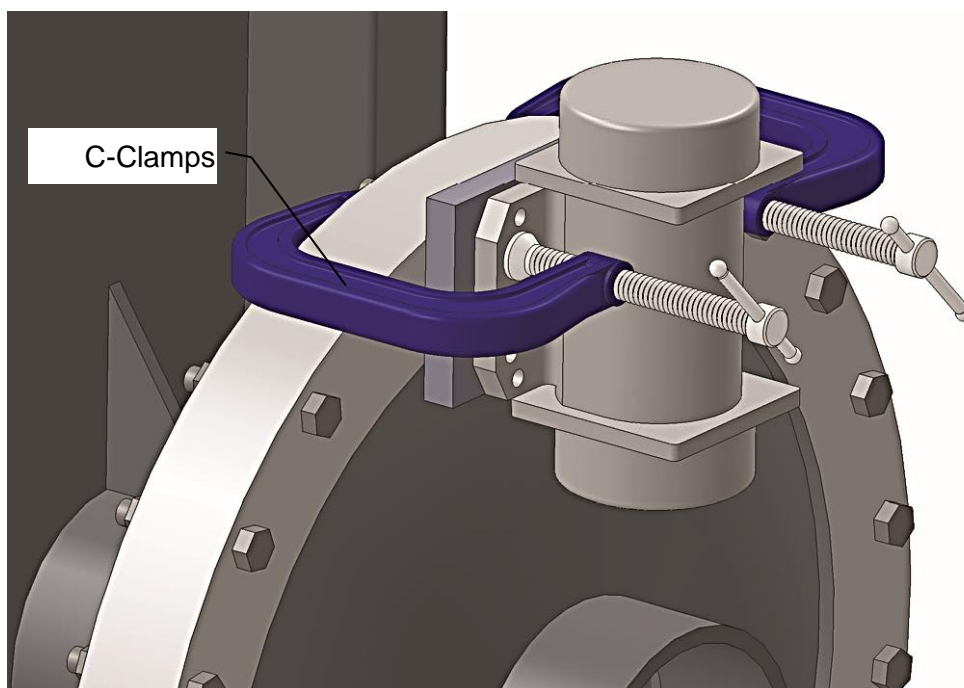

4. Plug shaker into 120 V power source and ensure that clamps stay firmly attached.
5. Unplug after catalyst filling operation is complete.